

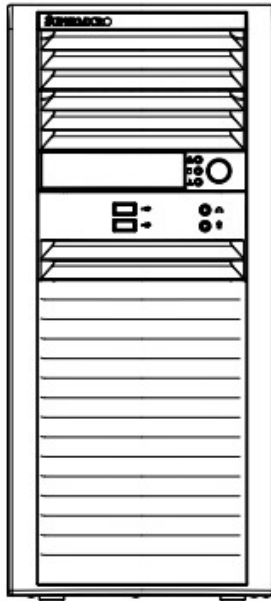

PW-GT20 Server



User Manual

Revision 2.0

Revision Date: 3.22.2022



The information in this User's Manual has been carefully reviewed and is believed to be accurate. The vendor assumes no responsibility for any inaccuracies that may be contained in this document and makes no commitment to update or to keep current the information in this manual, or to notify any person or organization of the updates. Please Note: For the most up-to-date version of this manual, please see our website at www.acecomputers.com.

Ace Computers reserves the right to make changes to the product described in this manual at any time and without notice. This product, including software and documentation, is the property of Ace Computers and/ or its licensors, and is supplied only under a license. Any use or reproduction of this product is not allowed, except as expressly permitted by the terms of said license.

IN NO EVENT WILL Ace Computers BE LIABLE FOR DIRECT, INDIRECT, SPECIAL, INCIDENTAL, SPECULATIVE OR CONSEQUENTIAL DAMAGES ARISING FROM THE USE OR INABILITY TO USE THIS PRODUCT OR DOCUMENTATION, EVEN IF ADVISED OF THE POSSIBILITY OF SUCH DAMAGES. IN PARTICULAR, SUPER MICRO COMPUTER, INC. SHALL NOT HAVE LIABILITY FOR ANY HARDWARE, SOFTWARE, OR DATA STORED OR USED WITH THE PRODUCT, INCLUDING THE COSTS OF REPAIRING, REPLACING, INTEGRATING, INSTALLING OR RECOVERING SUCH HARDWARE, SOFTWARE, OR DATA.

Any disputes arising between manufacturer and customer shall be governed by the laws of Cook County in the State of Illinois, USA. The State of Illinois, County of Cook shall be the exclusive venue for the resolution of any such disputes. Ace Computer's total liability for all claims will not exceed the price paid for the hardware product.

FCC Statement: This equipment has been tested and found to comply with the limits for a Class A digital device pursuant to Part 15 of the FCC Rules. These limits are designed to provide reasonable protection against harmful interference when the equipment is operated in an industrial environment. This equipment generates, uses, and can radiate radio frequency energy and, if not installed and used in accordance with the manufacturer's instruction manual, may cause harmful interference with radio communications. Operation of this equipment in a residential area is likely to cause harmful interference, in which case you will be required to correct the interference at your own expense.

The products sold by Ace Computers are not intended for and will not be used in life support systems, medical equipment, nuclear facilities or systems, aircraft, aircraft devices, aircraft/emergency communication devices or other critical systems whose failure to perform be reasonably expected to result in significant injury or loss of life or catastrophic property damage. Accordingly, Ace Computers disclaims any and all liability, and should buyer use or sell such products for use in such ultra-hazardous applications, it does so entirely at its own risk. Furthermore, buyer agrees to fully indemnify, defend and hold Ace Computers harmless for and against any and all claims, demands, actions, litigation, and proceedings of any kind arising out of or related to such ultra-hazardous use or sale.

Unless you request and receive written permission from Ace Computers, you may not copy any part of this document. Information in this document is subject to change without notice. Other products and companies referred to herein are trademarks or registered trademarks of their respective companies or mark holders.

Printed in the United States of America

Note: This User Manual was derived from a SuperMicro User Manual, with permission from SuperMicro, to include ACE Computers specific documentation.



Preface

About this Manual

This manual is written for professional system integrators and PC technicians. It provides information pertaining to EPEAT for the ACE Computers EPEAT registered servers.

Notes

If you have any questions regarding this manual or server system, please contact our support team through Ace Computers Support page <https://acecomputers.com/support/>. This manual may be periodically updated without notice.

Please check the Ace Computers website for possible updates to the manual revision level.

Table of Contents

Table of Contents

Chapter 1 - European Union (EU) Ecodesign Requirements	Error! Bookmark not defined.
Chapter 2 - Illustrated System Disassembly Instructions	6
1. Data Storage Devices	7
2. Memory	8
3. Processor	9
4. Motherboard	11
5. Expansion Card/Graphics Card	12
6. Power Supply Module	13
7. Side Panel	14
8. Batteries	15
9. Chassis Front Cover	16
10. Fans	18
11. External Power Cable	19
Chapter 3 – Installation, Maintenance and Replacement Instructions	20
3.0 Removing Power	20
3.1 Accessing the System	21
3.2 Motherboard Components	22
3.3 Memory (Replacement/Installation)	27
3.3 Memory (Replacement/Installation)	Error! Bookmark not defined.
3.4 Data Storage Devices (Replacement/Installation)	28
3.5 Fans (Replacement/Installation)	29
3.6 Power Supply (Replacement/Installation)	30
3.6 Expansion Card/Graphics Card (Replacement/Installation)	31
Chapter 4 – Product Take-Back, End-Of-Life Processing, and E-Waste Program	32
Chapter 5 – Product Services	32
5.1 Where to Get Replacement Components/Product Services	32
5.2 Returning Merchandise for Service	32

Chapter 1 – Testing/Compatibility Information

1. Operating Condition Class

The operating condition class is A2. Based on the results of testing, it was determined that as long as the server functions inside the Allowable Range as noted for “Operating Condition A2” (noted in the table below), there will be no material affect to the system and will continue to operate as intended for the entire lifecycle of the product.

The life expectancy of the server system is eight year on average. If the server runs for 18 hours a day, seven days a week for eight years, the operating hours that the server can operate in the allowable range for class A2 without becoming materially affected would be 52,560 hours.

Operating condition	Dry bulb temp °C		Humidity range, non-condensing		Max dew point (°C)	Maximum rate of change
	Allowable range	Recommend	Allowable range	Recommended range		
A1	15- 32	18-27	- 12 °C Dew Point (DP) and 8 % relative humidity (RH) to 17 °C DP and 60 % RH	- 9 °C DP to 15 °C DP and 60 %	17	5/20
A2	10-35	18-27	- 12 °C DP and 8 % RH to 21 °C DP and 80 %	Same as A1	21	5/20
A3	5-40	18-27	- 12 °C DP and 8 % RH to 24 °C DP and 85 %	Same as A1	24	5/20
A4	5-45	18-27	- 12 °C DP and 8 % RH to 24 °C DP and 90 %	Same as A1	24	5/20

Chapter 2 - Illustrated System Disassembly Instructions

Chapter 8 is intended to provide guidance to recyclers on the presence of materials and components at the product/family level, per Article 15 of the EU WEEE Directive 2012/19/EU. The provided information should also help direct recyclers to proper methods for removing parts and general product disassembly instructions. This Chapter also outlines specific substances, mixtures, and components that must be removed from any separately collected electronic waste component and shall be disposed or recovered in compliance with Directive 2008/98/EC.

Please note: All the illustrations in the below disassembly instructions are for demonstration only. The system and components shown in this section are a representative sample.

CAUTION: Always power off the system and unplug the power cord(s) first before disassembling the system!

Representative Server Component Layout

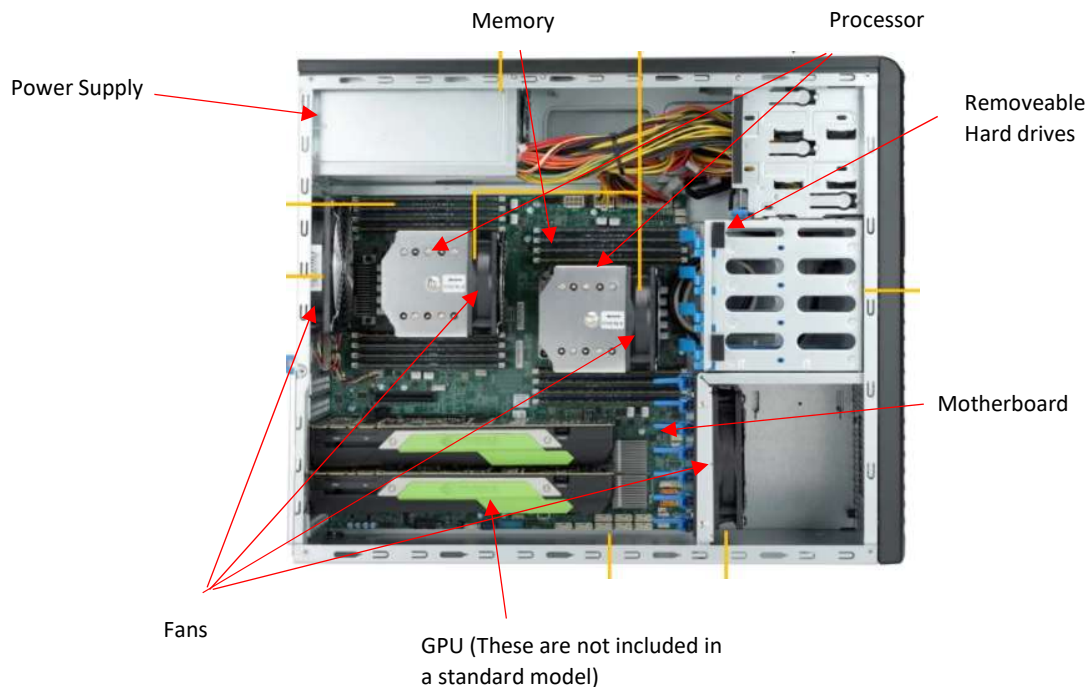

2. Data Storage Devices

Location: Servers are best known for their storage and interchangeability, within this tower model of server there's internal and external storage capacity. The internal storage is noted in the diagram below. Some models may also include interchangeable storage that can be accessed from the front panel. Some servers may also have SSD storage, this type of storage can be found on the motherboard. It generally lays flat, parallel to the board, rather than at a right angle. Most common applications insert one end of the SSD into a slot on the motherboard while the alternate end is held in place with a small screw.

Type and number of fastenings: HDD = One (1) latch and four (6) Phillips screws, SSD = (1) Phillips screw.

Tools required: Screwdriver with PH2 bit.

Procedure:

Step 1: HDD (3.5") = Push the release button on the carrier. Swing the carrier perpendicular to the chassis. Grasp the handle and pull the drive carrier out of its bay, once the drive carrier is out of the bay, the Phillips screws can be removed.

Step 2: SSD (2.5") = Identify the SSD on the motherboard, remove the screw, and pull straight back in a parallel position to remove the SSD from the slot on the motherboard.

Selective Treatment/Special Handling Per Annex VII, Directive 2012/19/EU: There are two printed circuit board present that are greater than 10 square centimeters, one within the HDD and one within SSD that must be removed separately from the data storage device and shall be disposed or recovered in compliance with Directive 2008/98/EC.

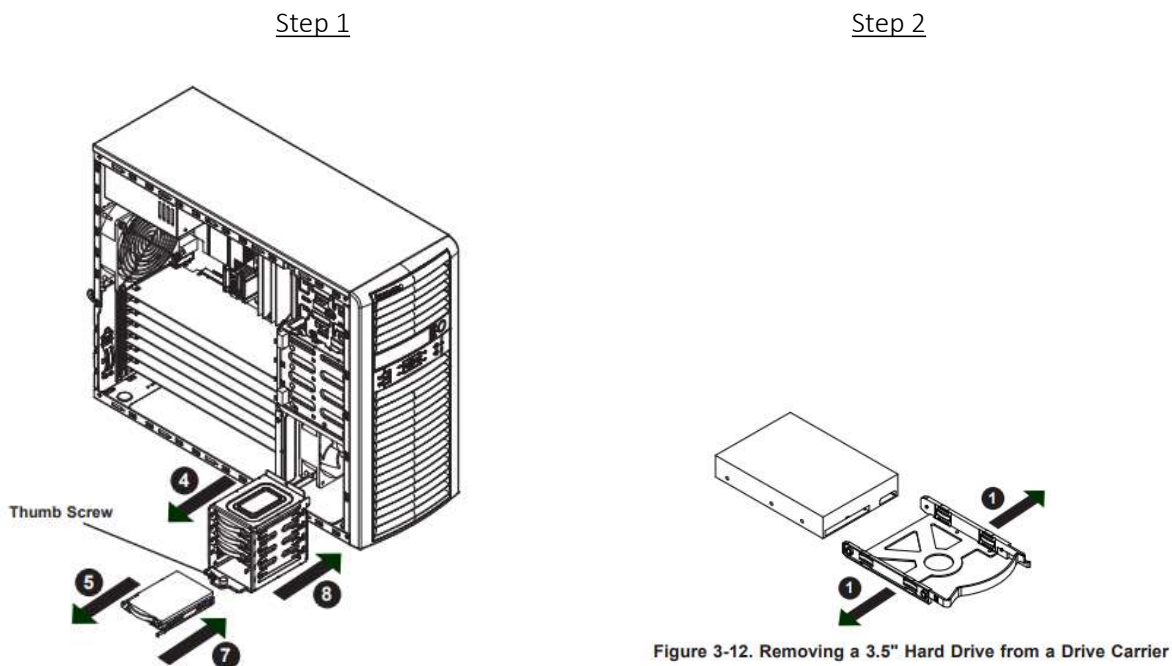

3. Memory

Location: Memory modules are found on the motherboard of the server, the number of memory modules may vary by unit configuration but are generally found in pairs of 2.

Type and number of fastenings: Two (2) latches per memory module.

Tools required: None.

Procedure: Press both release tabs on the ends of the memory module to unlock it. Once the module is loosened, remove it from the memory slot.

Selective Treatment/Special Handling Per Annex VII, Directive 2012/19/EU: The memory stick is a printed circuit board greater than 10 sq. cm and shall be disposed or recovered in compliance with EU Directive 2008/98/EC.

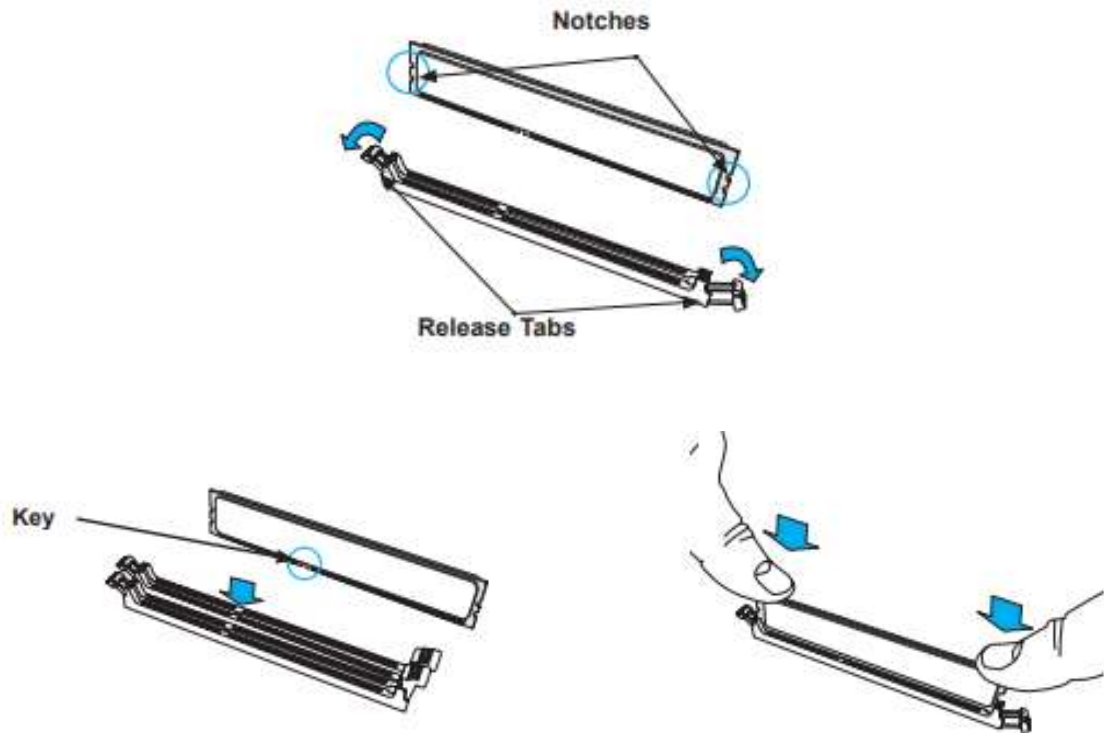

4. Processor

Location: The processor is found on the motherboard of the server. As shown in the photo below, the processor is located under the heat sink. The heatsink can look more like a fin type thermal transfer device, or a rotating fan with a thermal transfer plate. There can be more than one processor per motherboard, generally between 1- 4.

Type and number of fastenings: Four (4) T30 Torx screws.

Tools required: Screwdriver with T30 Torx bit.

Procedure: Remove the screws in the sequence of 4, then 3, then 2, then 1, as marked in the illustration below. After removing the screws, lift the processor heatsink module off the processor socket. Unsnap corners A and B, then C and D of the latch. Push the latch out from the bottom.

Selective Treatment/Special Handling Per Annex VII, Directive 2012/19/EU: The CPU does not contain any printed circuit boards.

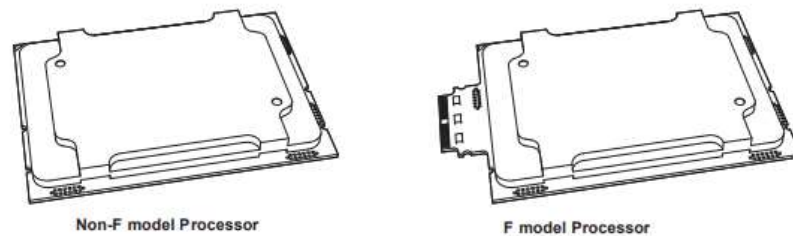

Figure 3-2. Xeon Scalable Processors

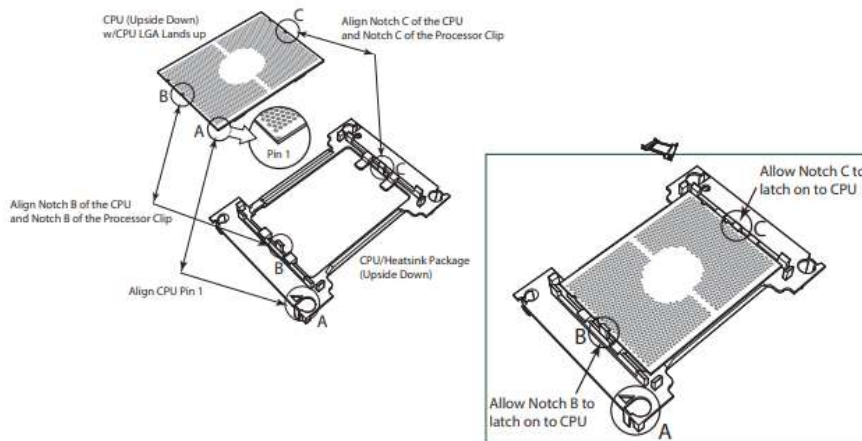

Figure 3-2. Processor Package Assembly for the non-F Model Processors

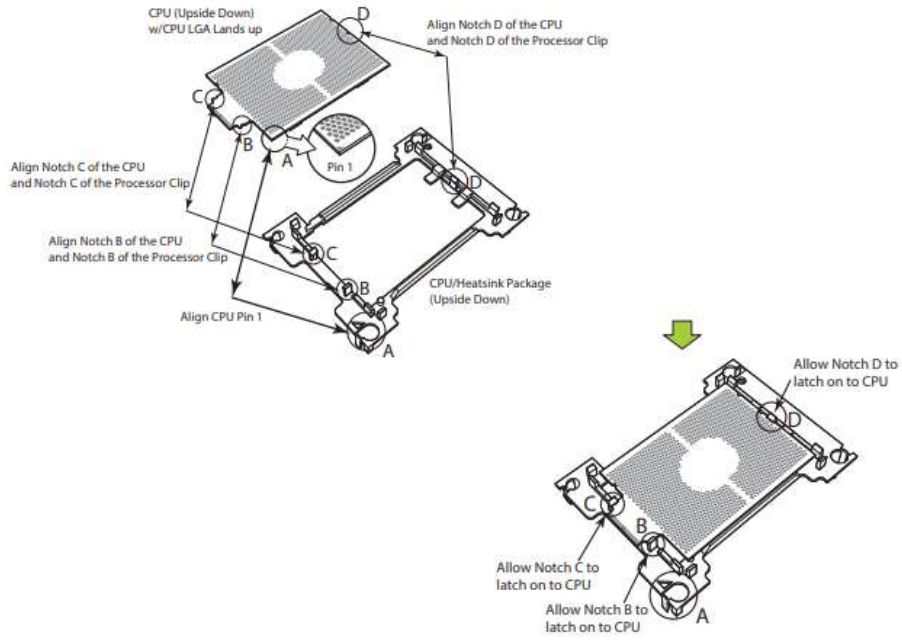
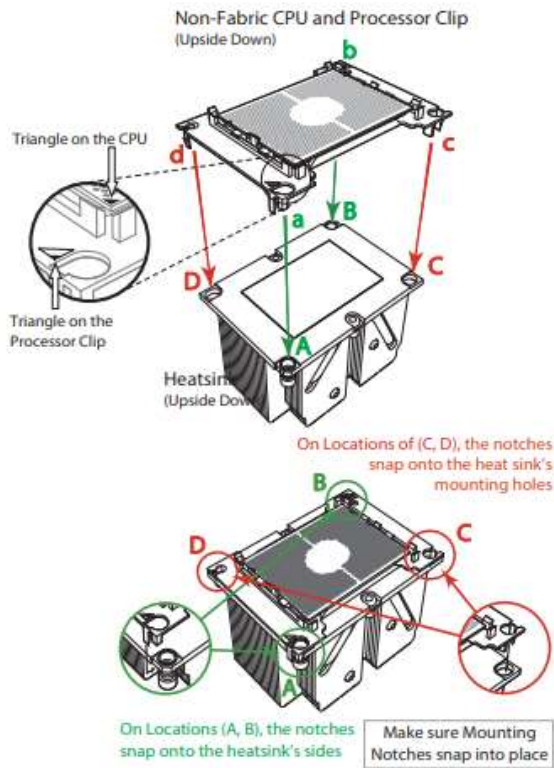

Figure 3-3. Processor Package Assembly for the F Model Processors



5. Motherboard

Location: The motherboard is the largest PCB in the server configuration, it is generally centrally located within the unit. Standard practice would be to remove all the components, peripherals, and add-ons from the motherboard before removal of the motherboard for processing.

Type and number of fastenings: 14 Phillips screws.

Tools required: Screwdriver with PH2 bit.

Procedure: Remove all 14 Phillips screws. Lift the motherboard from its base.

Selective Treatment/Special Handling Per Annex VII, Directive 2012/19/EU: The motherboard is a circuit board that is greater than 10 sq. cm and should be disposed or recovered in compliance with Directive 2008/98/EC.

A lithium battery resides on the motherboard. The battery must be removed separately from the motherboard and shall be disposed or recovered in compliance with Directive 2008/98/EC. Refer to section 9 for specific instructions on remove and disposal of LiON batteries.

- Handle used batteries carefully. Do not damage the battery in any way; a damaged battery may release hazardous materials into the environment. Do not discard a used battery in the garbage or a public landfill. Please comply with the regulations set up by your local hazardous waste management agency to dispose of your used battery properly.

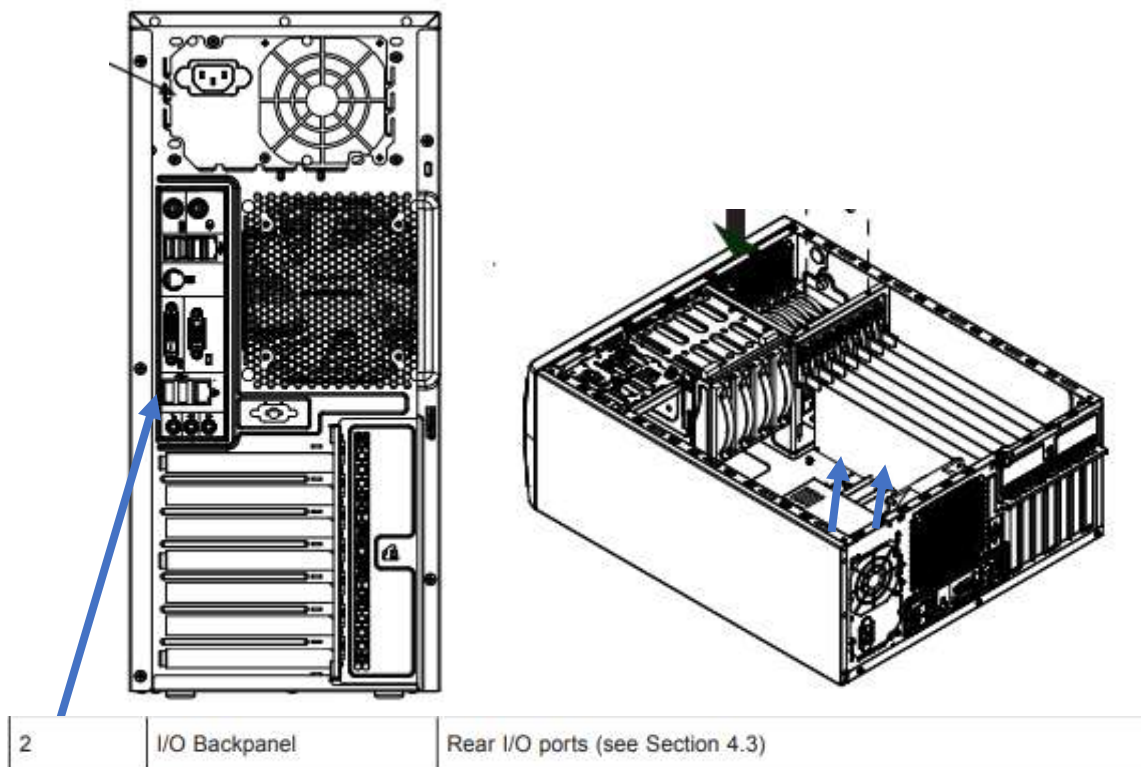

6. Expansion Card/Graphics Card

Location: Certain configurations of server may include one or more graphics cards/GPUs, these are connected to the motherboard in a perpendicular orientation and are fastened to the chassis for support.

Type and number of fastenings: Six (6) Phillips screws.

Tools required: Screwdriver with PH2 bit.

Procedure: Remove the Phillips screws. Open the rear window latch and carefully remove the expansion card from the riser card slot, lifting it up and away from the system.

Selective Treatment/Special Handling Per Annex VII, Directive 2012/19/EU: There is one printed circuit board present that is greater than 10 square centimeters within each expansion card/graphics card that must be removed separately from the data storage device and shall be disposed or recovered in compliance with Directive 2008/98/EC.

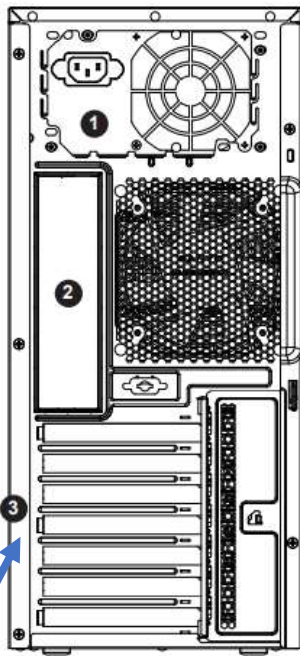
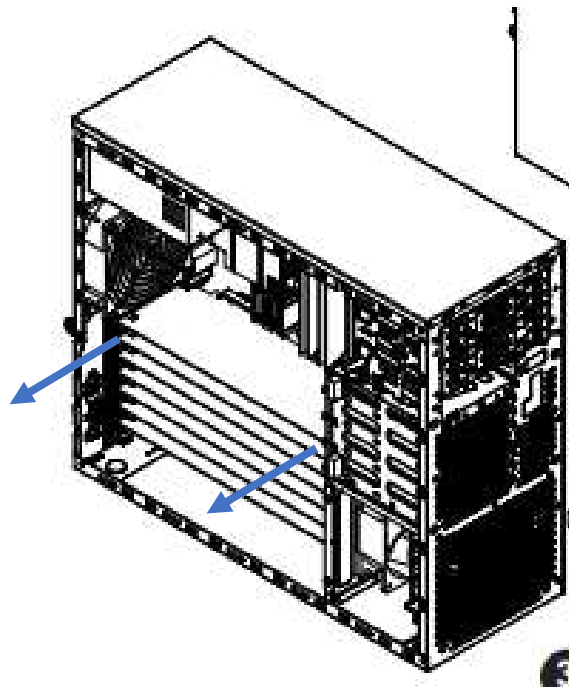

Figure 1-3. Chassis Rear View



3	PCI Slots	Supports seven full-height, full-length PCI expansion cards
---	-----------	-------------------------------------------------------------

7. Power Supply Module

Location: The power supply module is located on the top left-hand corner connected directly to the chassis.

Type and number of fastenings: Four Phillips screws.

Tools required: Screwdriver with PH2 bit.

Procedure: Unplug the power cord from the power supply. Push the release tab on the back of the power supply module to the side and pull the module straight out.

Selective Treatment/Special Handling Per Annex VII, Directive 2012/19/EU: The power supply module is a circuit board that is greater than 10 sq. cm and should be disposed or recovered in compliance with Directive 2008/98/EC.

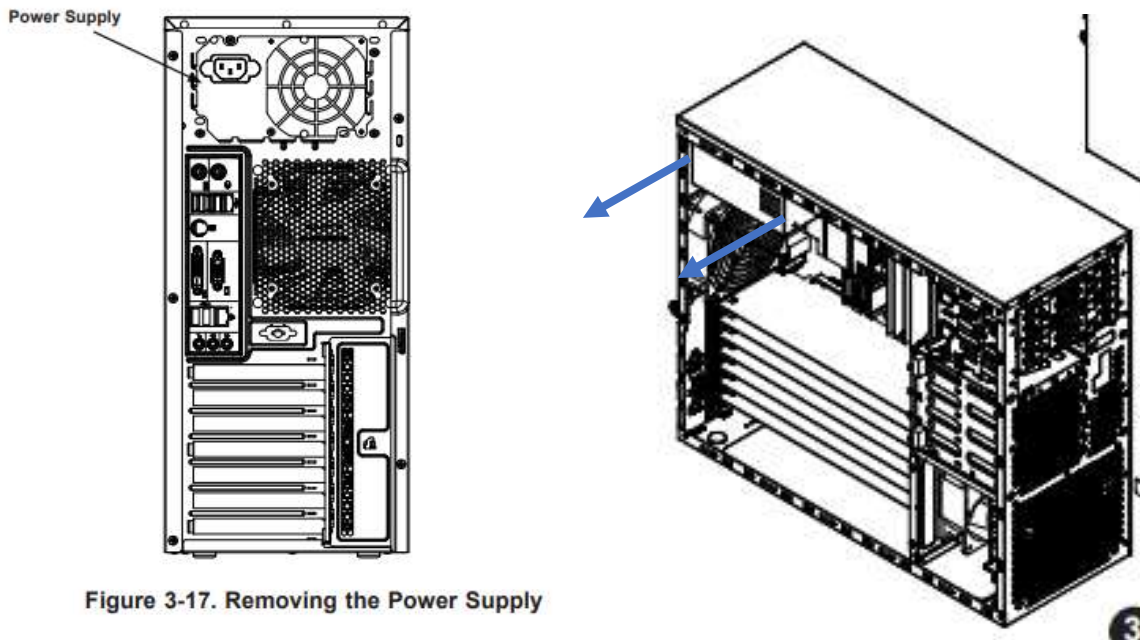

Figure 3-17. Removing the Power Supply

8. Side Panel

Location: There are two side panels and depending on configuration, may be attached by interference fit, or thumb screws, or regular screws.

Type and number of fastenings: May vary from none up to five in total.

Tools required: None.

Procedure: If there are screws, remove the screws and apply medium pressure and slide directly back to remove.

Selective Treatment/Special Handling Per Annex VII, Directive 2012/19/EU: None

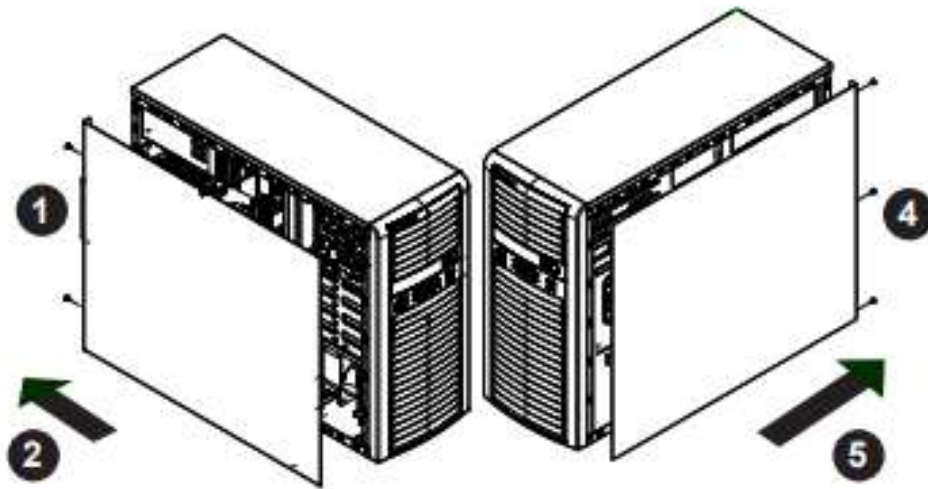

9. Batteries

Location: The battery is located on the motherboard, see illustration below.

Type and number of fastenings: One (1) latch.

Tools required: None.

Procedure: Push aside the small clamp that covers the edge of the battery. When the battery is released, lift it out of the holder.

Selective Treatment/Special Handling Per Annex VII, Directive 2012/19/EU: A lithium battery resides on the motherboard. The battery must be removed from separately from the motherboard and shall be disposed or recovered in compliance with Directive 2008/98/EC. Removal instructions for the motherboard lithium battery are outlined below.

- Handle used batteries carefully. Do not damage the battery in any way; a damaged battery may release hazardous materials into the environment. Do not discard a used battery in the garbage or a public landfill. Please comply with the regulations set up by your local hazardous waste management agency to dispose of your used battery properly.

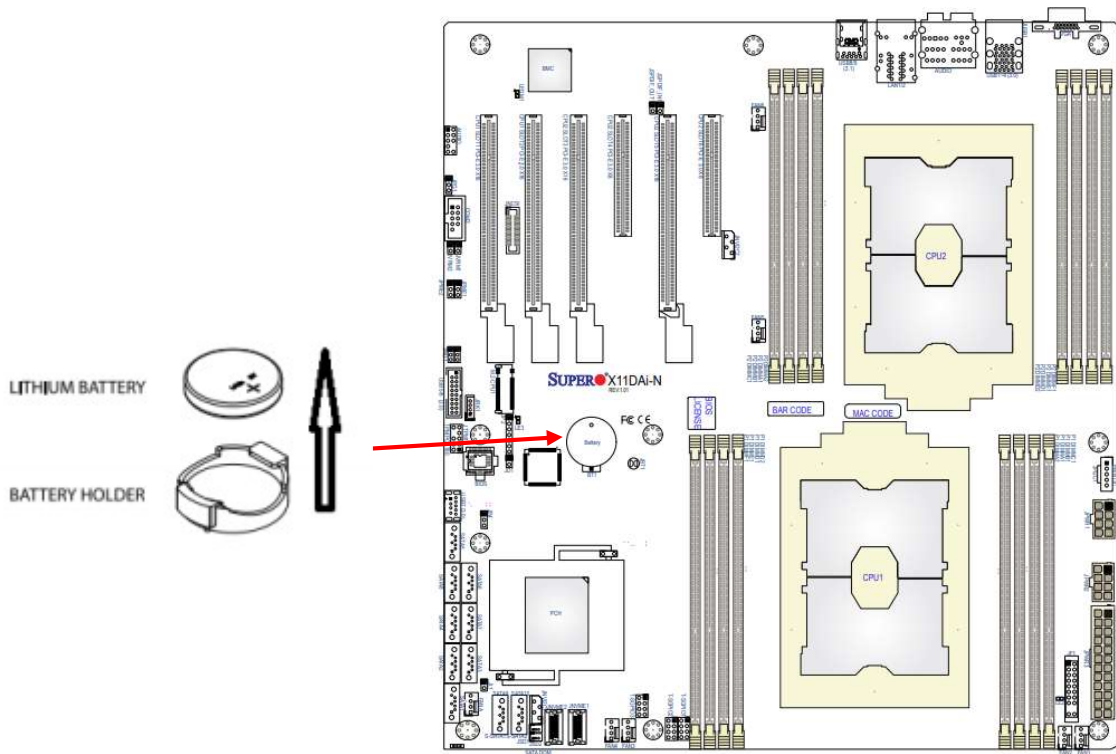

Figure 1-4. Motherboard Layout

10. Chassis Front Cover

Location: The Chassis front cover is located on the front of the server system. Depending on the configuration, there may be two plastic components. One large cover and one small covering expandable drive bay options. Unless the drive bay options are utilized, then there would only be one cover.

Type and number of fastenings: Plastic clasps

Tools required: Flat Screwdriver

Procedure:

Step 1: Remove the front bezel from the chassis by lifting it upwards from the bottom and pulling off the front of the chassis.

Step 2: Remove the cover plate from the front of the chassis using a flat screwdriver to unlock the plastic hooks.

Selective Treatment/Special Handling Per Annex VII, Directive 2012/19/EU: None

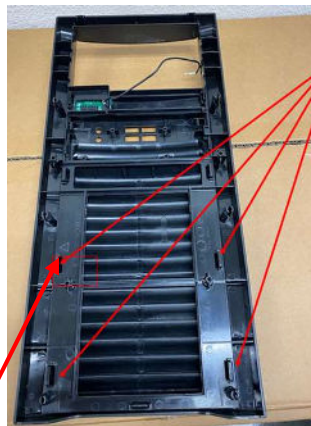
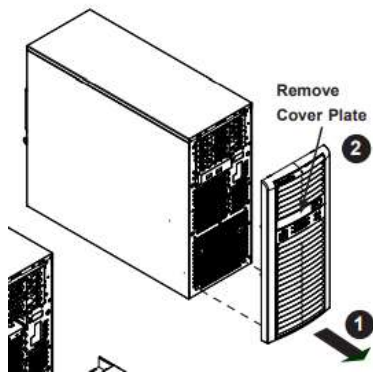

- Use Flat-screwdriver to unlock the plastic hook.
- Venting cover will pop off.



For the vent cover, use flat-screwdriver to push out and pop off part:



11. Fans

Location: Most servers are equipped with a number of fans, this configuration includes no less than 2 fans. One fan is located directly below the power supply in the rear of the chassis. The second is located in a position to cool the hard drives. Additional fans may be added for different configurations. See illustration noted below for location within the server chassis.

Type and number of fastenings: One (1) fan header per fan.

Tools required: None.

Procedure: Disconnect the fan wiring from the fan header on the motherboard. Then remove the fan from the fan tray.

Selective Treatment/Special Handling Per Annex VII, Directive 2012/19/EU: Any plastic components within the fan must be removed separately due to the presence of brominated flame retardants and shall be disposed or recovered in compliance with Directive 2008/98/EC.

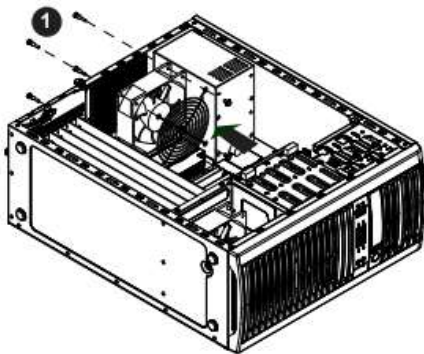

Figure 3-15. Replacing the System Fan

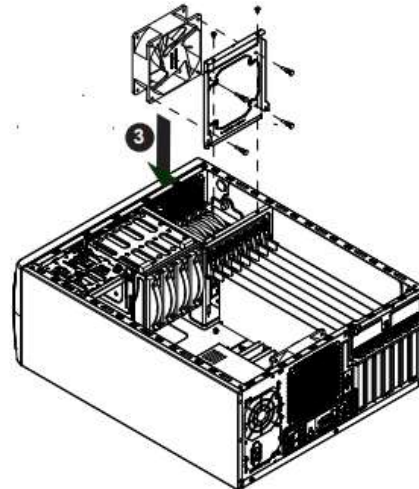

Figure 3-16. Installing the Front Cooling Fan (Optional)

12. External Power Cable

Location: To power the server a power cable is required. The cable may be separate or attached via a server rack mount power delivery system. The external power cable may be dual ended with an outlet and inlet of the same plug configuration type or one end may be a plug type connection. Configurations may vary. If the server is fully configured, the power supply cord would be connected to the power supply outlet located on the rear of the server chassis. Note: there are two power supplies per unit, so be aware for two power supply cords.

Type and number of fastenings: None, direct pressure connection method.

Tools required: None.

Procedure: Disconnect the external power cable from the main server assembly.

Selective Treatment/Special Handling Per Annex VII, Directive 2012/19/EU: Any external electrical cables must be removed separately and shall be disposed or recovered in compliance with Directive 2008/98/EC.

Chapter 3 – Installation, Maintenance and Replacement Instructions

This chapter provides instructions on installing and replacing main system components. To prevent compatibility issues, only use components that match the specifications and/or part numbers given.

Installation or replacement of most components require that the power first be removed from the system. Please follow the procedures given in each section.

Additional information regarding replacement components/availability can be found in Chapter 5 below.

3.0 Removing Power

Use the following procedure to ensure that power has been removed from the system. This step is necessary when removing or installing non hot-swap components or when replacing a non-redundant power supply.

1. Use the operating system to power down the system.
2. After the system has completely shut-down, disconnect the AC power cord(s) from the power strip or outlet.
3. Disconnect the power cord(s) from the power supply module(s).

3.1 Accessing the System

The chassis has two removable side covers, allowing easy access to the chassis interior.

Removing the Side Cover

Begin by removing power from the system as described in Section 3.1.

1. Remove the two screws securing the left side cover to the chassis.
2. Slide the left cover toward the rear of the chassis.
3. Lift the left cover from the chassis.
4. Remove the three screws securing the right-side cover to the chassis.
5. Slide the right cover toward the rear of the chassis.
6. Lift the right cover from the chassis.

Warning: Except for short periods of time, do not operate the server without the cover in place. The chassis cover must be in place to allow for proper airflow and to prevent overheating.

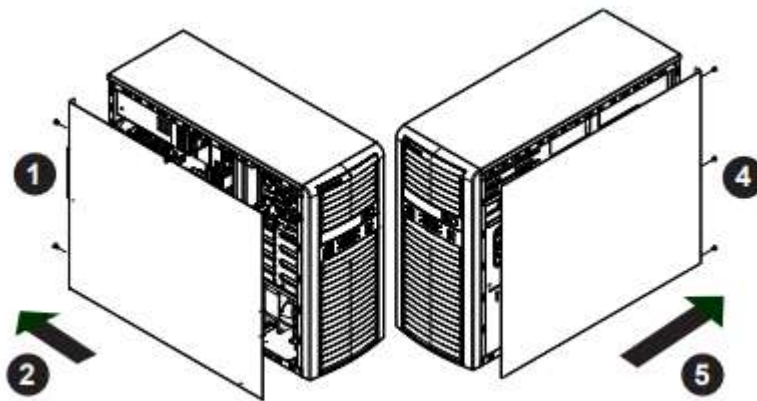

3.2 Motherboard Components

Processor and Heatsink Installation

The processor (CPU) and heatsink should be assembled together first to form the processor heatsink module (PHM), and then install the PHM into the CPU socket.

Notes:

- All power should be off before installing the processors.
- When handling the processor package, avoid placing direct pressure on the label area of the CPU or socket.
- Check that the plastic socket dust cover is in place and none of the socket pins are bent.
- Graphics in this manual are for illustration. Your components may look slightly different.

The Xeon Scalable Processor

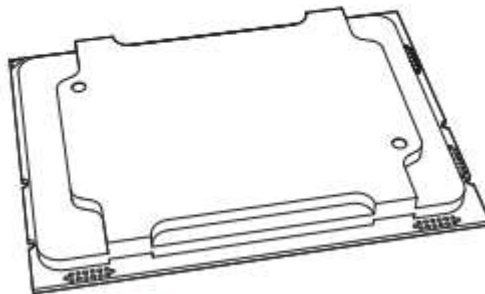

Non-F model Processor

Assembling the Processor Package

Attach the processor to the thin processor clip to create the processor package.

1. On the top corner of the CPU, locate pin 1 (A), marked by a triangle. Also, locate notch B and notch C on the CPU as shown below.
2. On the top of the processor clip, locate the corner marked by a hollow triangle as the position for pin 1. Also locate notch B and notch C on the processor clip.
3. Align pin 1 of the CPU with its proper position on the processor clip and carefully insert the CPU into the processor clip. Slide notch B of the CPU into tab B of the processor clip, and slide notch C of the CPU into tab C of the processor clip until the processor clip tabs snap onto the CPU.
4. Examine all corners to ensure that the CPU is properly seated and secure on the processor clip.

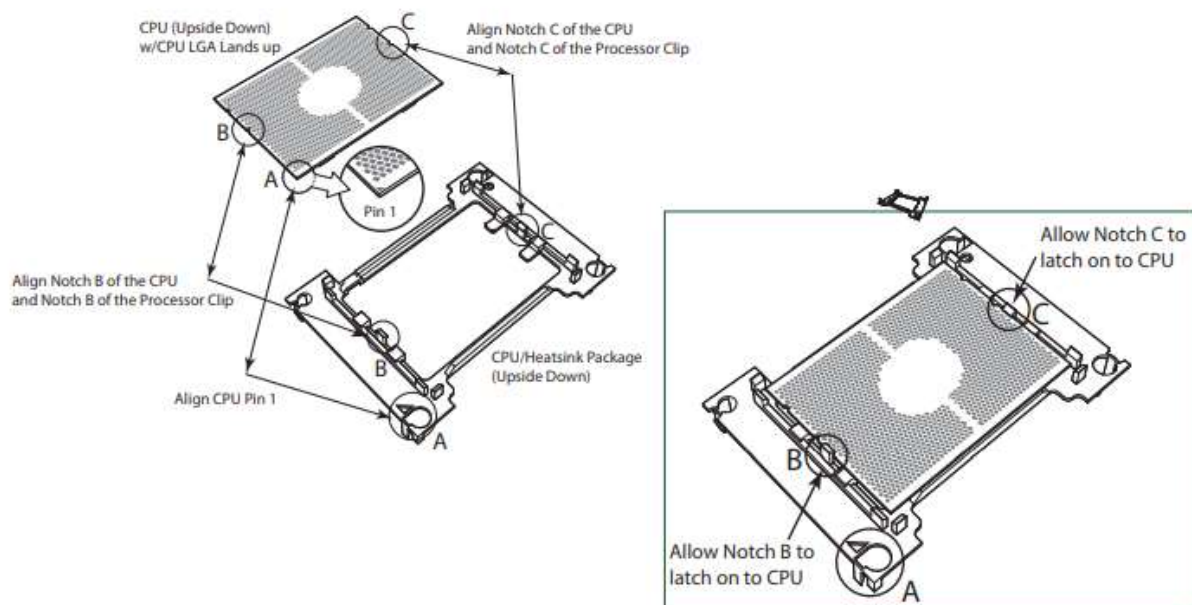

Assembling the Processor Heatsink Module (PHM)

After creating the processor package assembly, mount it onto the heatsink to create the processor heatsink module (PHM).

1. On the heatsink label, locate “1” and the corner next to it. Turn the heatsink upside down with the thermal grease side facing up, keeping track of the “1” corner.
2. Remove the protective thermal film if present. If this is a new heatsink, the necessary thermal grease has been pre-applied in the factory. If the heatsink is not new, apply the proper amount of thermal grease.
3. In the plastic processor clip, locate the hollow triangle at the corner (“a” in the drawing below) next to a hole and plastic mounting clips. There is a similar hole and mounting clips at the diagonal corner of the processor clip (“b” in the drawing).
4. With the underside of the heatsink and the underside of the processor package facing up, align the “1” corner on the heatsink (“A” in the drawing) against the mounting clips next to the hollow triangle (“a”) on the processor package.
5. Also align the corner (“B”) at the diagonal side of the heatsink with the corresponding clips on the processor package (“b”).
6. Once aligned, press the processor package assembly onto the heatsink until the mounting clips (at a, b, c, and d) snap into place.

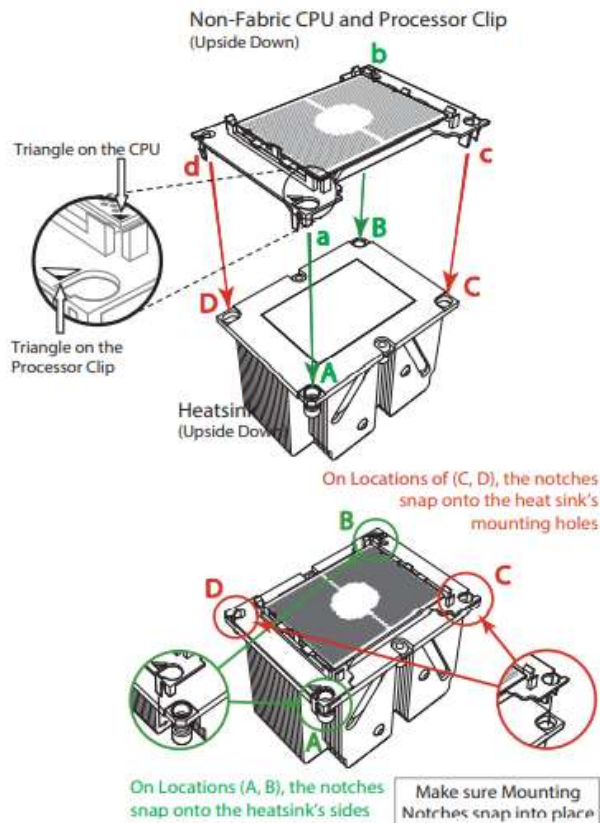

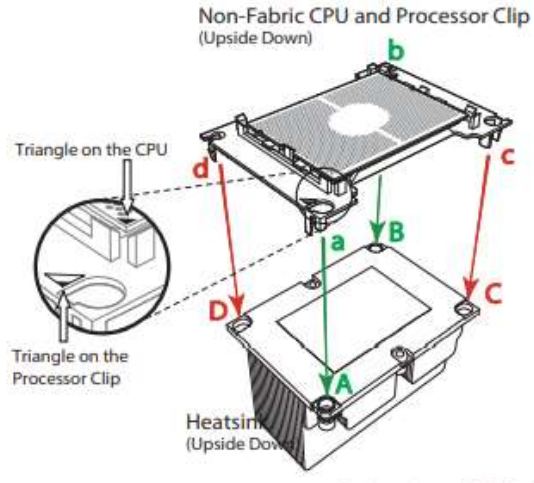

Removing the Dust Cover from the CPU Socket

Remove the dust cover from the CPU socket, exposing the socket pins as shown below.

Caution: Do not touch the socket pins.

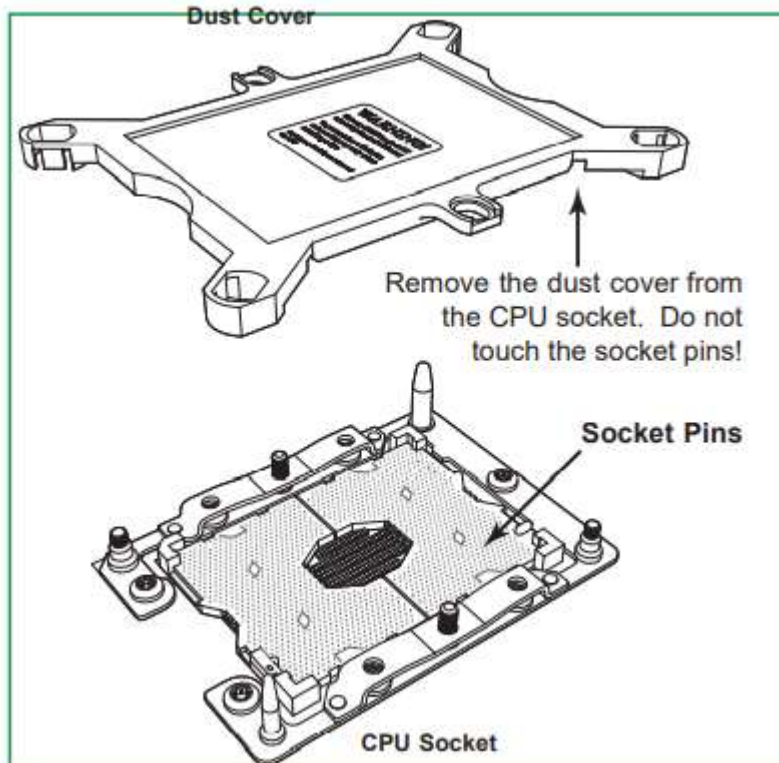

Installing the Processor Heatsink Module (PHM)

1. Locate the triangle (pin 1) on the CPU socket. Also locate the pin 1 corner of the PHM that is closest to "1" on the heatsink label. To confirm, look at the underside of the PHM and note the hollow triangle in the processor clip and printed triangle on the CPU located next to a screw at the corner.
2. Align the pin 1 corner of the PHM over the pin 1 corner on the CPU socket.
3. Align the two holes at diagonal corners of the PHM onto the two guide posts on the socket bracket and carefully lower the PHM onto the socket.
4. Use a T30 Torx-bit screwdriver to install four screws into the mounting holes on the socket to securely attach the PHM onto the motherboard in the sequence of 1, 2, 3, and 4, as marked on the heatsink label. Gradually tighten each to assure even pressure.

Note: Use only 12 foot-pounds of torque when tightening the screws to avoid damaging the processor or the socket.

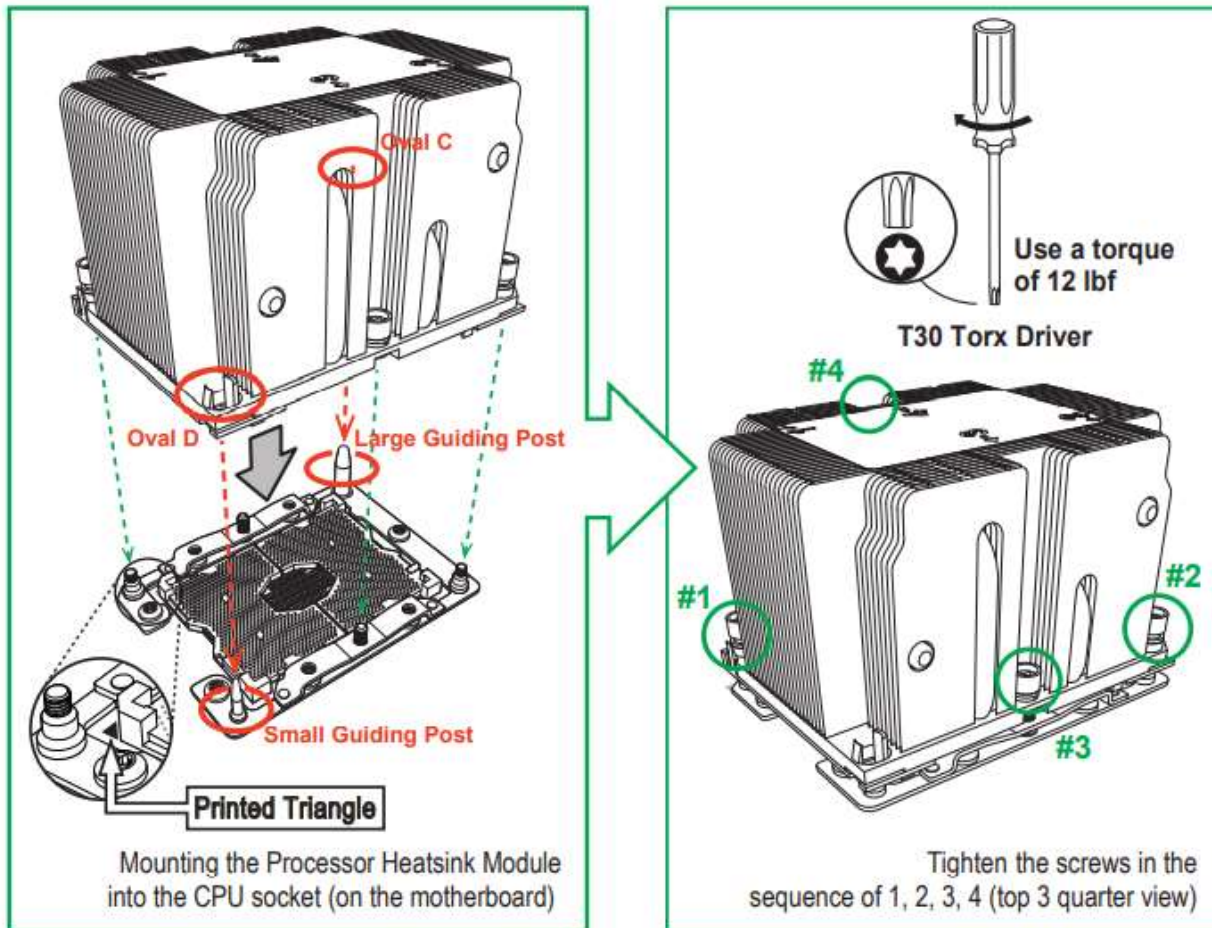

3.3 Memory (Replacement/Installation)

Type and number of fastenings: Two (2) latches per memory module.

Tools required: None.

Procedure:

1. Once you have followed the entire disassembly instructions under the Memory Disassembly Section (Chapter 2) above, unpack the new memory.
2. Ensure the notches on both sides line up with the release tabs, apply light pressure and push down to secure the memory notches into the release tabs (outlined below).

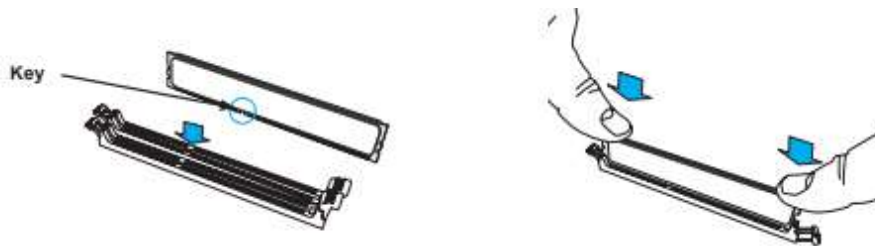

3.4 Data Storage Devices (Replacement/Installation)

Type and number of fastenings: HDD = One (1) latch and four (6) Phillips screws, SSD = (1) Phillips screw.

Tools required: Screwdriver with PH2 bit.

Procedure:

1. Once you have followed the entire disassembly instructions under Data Storage Devices Disassembly (Chapter 2) above, unpack the new HDD or SSD.
2. Remove the dummy drive, which comes pre-installed in the drive carrier, by removing the screws securing the dummy drive to the carrier. These screws are not used to mount the actual drive.

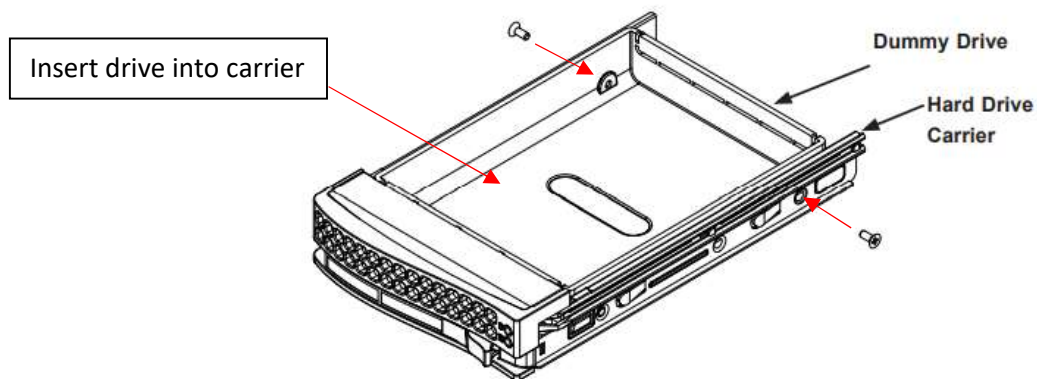

3. Insert a drive into the carrier with the PCB side facing down and the connector end toward the rear of the carrier. Align the drive in the carrier so that the screw holes line up. Note that there are holes in the carrier marked "SATA" to aid in correct installation.
4. Secure the drive to the carrier with four M3 screws as illustrated above. These screws are included in the chassis accessory box.
5. Insert the drive carrier with the disk drive into its bay, keeping the carrier oriented so that the hard drive is on the top of the carrier and the release button is on the right side. When the carrier reaches the rear of the bay, the release handle will retract.
6. Push the handle in until it clicks into its locked position.

3.5 Fans (Replacement/Installation)

Type and number of fastenings: One (1) fan header per fan.

Tools required: None.

Procedure:

Rear Exhaust Fan: Insert the four rubber pins into the four mounting holes surrounding the fan grill on the rear of the chassis. Pull the rubber pins through the mounting holes of the fan to secure the fan to the chassis. Connect the fan cable to the server board.

Front Cooling Fan: Insert the four rubber pins through the front fan bracket and into the mounting holes in the front fan. Pull the rubber pins through the mounting holes of the system fan to secure the fan to the chassis. Lower the fan into the chassis, aligning the holes at the top of the front fan bracket with the holes in the chassis. Secure the fan to the chassis using the two screws provided. Connect the fan cable to the server board.

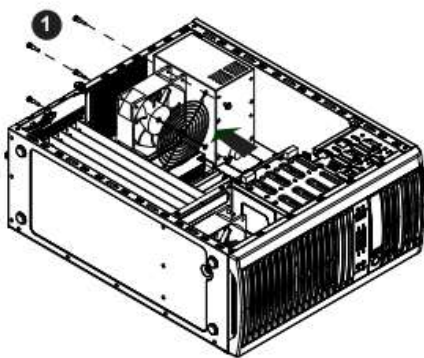

Figure 3-15. Replacing the System Fan

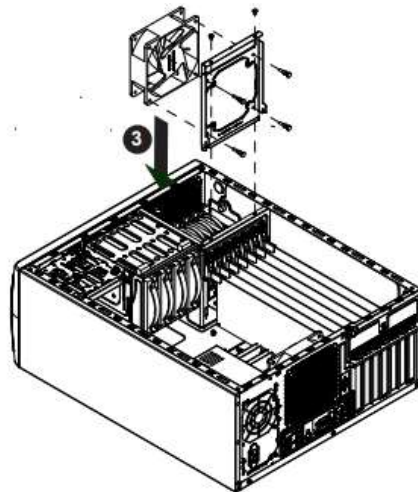

Figure 3-16. Installing the Front Cooling Fan (Optional)

3.6 Power Supply (Replacement/Installation)

Type and number of fastenings: Four Phillips screws.

Tools required: Screwdriver with PH2 bit.

Procedure: Replace the failed power supply with an identical power supply model. Secure the new power supply using the four Phillips screws. Plug the AC power cord back into the module and power-up the system.

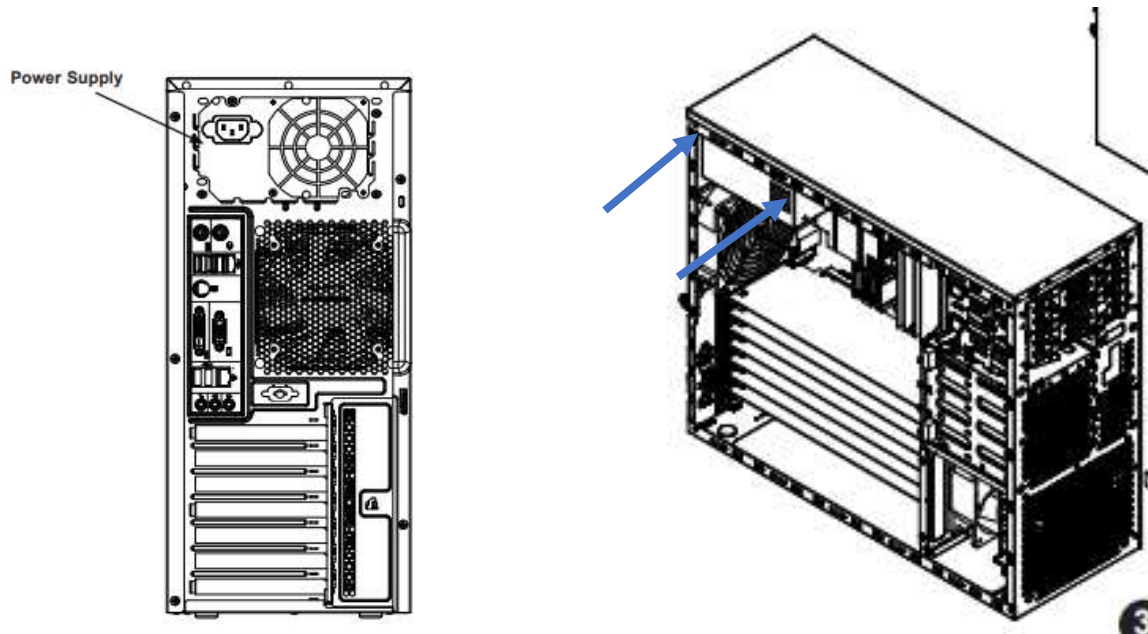

3.6 Expansion Card/Graphics Card (Replacement/Installation)

Type and number of fastenings: Six (6) Phillips screws.

Tools required: Screwdriver with PH2 bit.

Procedure: Once you have followed the entire disassembly instruction under the Expansion Card/Graphics Card Section (Chapter 2) above, unpack the new Expansion Card or Graphics Card.

Remove the Phillips screws. Open the rear window latch and carefully remove the expansion card from the riser card slot, lifting it up and away from the system.

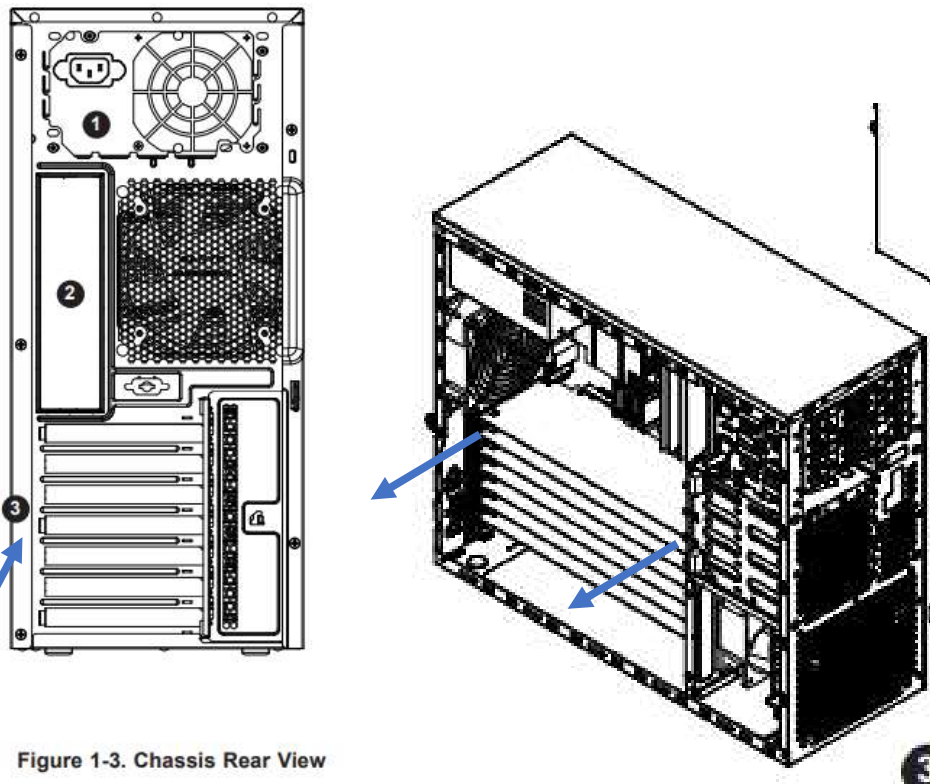

Figure 1-3. Chassis Rear View



Chapter 4 – Product Take-Back, End-Of-Life Processing, and E-Waste Program

Ace Computers offers a nationwide take-back service for proper end-of-life management of EPEAT-registered and Non-EPEAT registered products via Ace Computers and partnered with an R2-certified recycling facility.

For additional information and steps to take regarding our Product Take-Back, End-of-Life Processing, and E-Waste Program, please visit our website at <https://acecomputers.com/company/sustainability/> under the EPEAT Take-Back/EOL/E-Waste Program Tab.

Chapter 5 – Product Services

5.1 Where to Get Replacement Components/Product Services

If you need replacement parts or product service for your system, for self-replacement or for on-site replacement, please visit <https://acecomputers.com/support/> and fill out the Ace Computers Support Request form. If phone assistance is needed please call our Support Line 847-952-6999.

Note: Most parts/product services are available for at least 5 years after the date of sale. Replacement components at a minimum cover the following: power supply, fans, hard drives, memory, CPU, PCB assemblies, memory and all hardware.

5.2 Returning Merchandise for Service

Upon completion of the Ace Computers Support Request Form, indicated in Section 1.5, an Ace Computers Team Member will reach out to further assist with your technical questions. If it is determined that the best course of action is an inhouse repair at Ace Computers, the service technician will help facilitate the process of returning the server for repair.